

# TUBES et VERROUS



Les tubes vestibulaires Leone sont fabriqués en acier inoxydable selon la technologie “Metal Injection Moulding” qui permet d’obtenir une précision parfaite du slot et une forme particulièrement biseautée pour le maximum de confort pour le patient. Tous les tubes vestibulaires **MIM**® peuvent être présoudés sur les bagues **CALIBRA**® ou **WEB**®, le service de présoudage est gratuit, ou soudo-brasés sur la base anatomique à coller **MAXI F2800-00**, conçue avec l’anatomie spécifique pour la première molaire. Le service de soudo-brasage est gratuit.

Les verrous Leone sont fabriqués en acier inoxydable et sont micro-façonnés mécaniquement pour obtenir une meilleure précision au niveau des slots. La tolérance générale est inférieure à 3/100. Le bord des slots est scrupuleusement arrondi. Tous les verrous Leone peuvent être présoudés sur les bagues **CALIBRA**® ou **WEB**®, le service de présoudage est gratuit.



## technologie Metal Injection Moulding

permettant une précision parfaite du slot



## bords arrondis sous les ailettes

pour garantir le confort maximum du patient

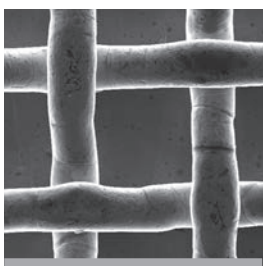

## service de soudage et de soudo-brasage gratuit



















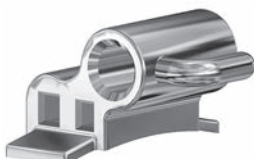













## TUBES VESTIBULAIRES MIM®

Ils peuvent être livrés présoudés sur les bagues **CALIBRA®** ou **WEB®** ou soudo-brasés sur la base anatomique à coller **MAXI F2800-00**: les services de présoudage (page 59) ou de soudo-brasage (page 110) sont gratuits.

Disponibles même en version à coller (page 108).

En paquets de 10





















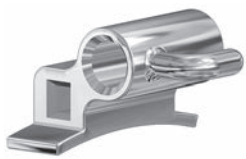







En paquets de 100, sur demande











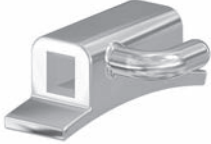





				torque	rotat. tube rect.	diam. tube rond	slot tube rect.	tubes à souder	
	$\frac{6}{16}$ $\frac{6}{16}$	  	0°		.045" occl.	.018"	D	<a href="#">G8084-22</a>	
						.022"	G	<a href="#">G8084-23</a>	
	$\frac{6}{16}$	  	0°		.051" occl.	.018"	D	<a href="#">G8085-12</a>	
						.022"	G	<a href="#">G8085-13</a>	
	$\frac{6}{16}$ $\frac{6}{16}$	  	-10°	+8°	.045" occl.	.018"	D	<a href="#">G8384-22</a>	
						.022"	G	<a href="#">G8384-23</a>	
	$\frac{6}{16}$	  	-10°	+8°	.051" occl.	.018"	D	<a href="#">G8385-12</a>	
						.022"	G	<a href="#">G8385-13</a>	
<b>tube auxiliaire .018"x.025"</b>									
	$\frac{6}{16}$ $\frac{6}{16}$	  	0°		.045" ging.	.018"	D	<a href="#">G8084-12</a>	
						.022"	G	<a href="#">G8084-13</a>	
	$\frac{6}{16}$	  	-10°	+8°	.045" ging.	.018"	D	<a href="#">G8384-12</a>	
						.022"	G	<a href="#">G8384-13</a>	
<b>tube auxiliaire .018"x.025"</b>									
	$\frac{6}{16}$ $\frac{6}{16}$	  	0°			.018"	D	<a href="#">G8070-16</a>	
						.022"	G	<a href="#">G8070-17</a>	
	$\frac{6}{16}$	  	-14°	+8°		.018"	D	<a href="#">G8070-02</a>	
						.022"	G	<a href="#">G8070-03</a>	
	$\frac{6}{16}$	  	-25°	+8°		.018"	D	<a href="#">G8070-06</a>	
						.022"	G	<a href="#">G8070-07</a>	
<b>tube auxiliaire .018"x.025"</b>									
							.018"	D	<a href="#">G8010-16</a>
							.022"	G	<a href="#">G8010-17</a>
							.018"	D	<a href="#">G8010-02</a>
							.022"	G	<a href="#">G8010-03</a>
							.018"	D	<a href="#">G8010-06</a>
							.022"	G	<a href="#">G8010-07</a>

## TUBES VESTIBULAIRES MIM®

En paquets de 10

En paquets de 100, sur demande

					torque	rotat. tube rect.	diam. tube rond	slot tube rect.	tubes à souder	
	6/6 6/6				0°		.045"	.018"	D <a href="#">G8084-32</a>	
							occl.		G <a href="#">G8084-33</a>	
								.022"	D <a href="#">G8024-32</a>	
										G <a href="#">G8024-33</a>
								.051"	.018"	D <a href="#">G8085-22</a>
								occl.		G <a href="#">G8085-23</a>
								.022"	D <a href="#">G8025-22</a>	
										G <a href="#">G8025-23</a>
6/6					-10°	+8°	.045"	.018"	D <a href="#">G8384-32</a>	
							occl.		G <a href="#">G8384-33</a>	
							.022"	D <a href="#">G8324-32</a>		
									G <a href="#">G8324-33</a>	
					-10°	+8°	.051"	.018"	D <a href="#">G8385-22</a>	
							occl.		G <a href="#">G8385-23</a>	
							.022"	D <a href="#">G8325-22</a>		
									G <a href="#">G8325-23</a>	
	6/6 6/6				0°		.045"	.018"	D <a href="#">G8084-02</a>	
							ging.		G <a href="#">G8084-03</a>	
								.022"	D <a href="#">G8024-02</a>	
										G <a href="#">G8024-03</a>
						0°		.051"	.018"	D <a href="#">G8085-02</a>
								ging.		G <a href="#">G8085-03</a>
								.022"	D <a href="#">G8025-02</a>	
										G <a href="#">G8025-03</a>
6/6					-10°	+8°	.045"	.018"	D <a href="#">G8384-02</a>	
							ging.		G <a href="#">G8384-03</a>	
							.022"	D <a href="#">G8324-02</a>		
									G <a href="#">G8324-03</a>	
					-10°	+8°	.051"	.018"	D <a href="#">G8385-02</a>	
							ging.		G <a href="#">G8385-03</a>	
							.022"	D <a href="#">G8325-02</a>		
									G <a href="#">G8325-03</a>	
6/6					-25°	+8°	.045"	.018"	D <a href="#">G8384-06</a>	
							ging.		G <a href="#">G8384-07</a>	
							.022"	D <a href="#">G8324-06</a>		
									G <a href="#">G8324-07</a>	
					-25°	+8°	.051"	.018"	D <a href="#">G8385-06</a>	
							ging.		G <a href="#">G8385-07</a>	
							.022"	D <a href="#">G8325-06</a>		
									G <a href="#">G8325-07</a>	

									
			torque	rotat. tube rect.	diam. tube rond	slot tube rect.	tubes à souder		
	7 6 6 7 7 6 6 7	  	0°			.018"	D <b>G8081-02</b> G <b>G8081-03</b>		
						.022"	D <b>G8021-02</b> G <b>G8021-03</b>		
	7 6 6 7	  	-10°	+8°			.018"	D <b>G8381-02</b> G <b>G8381-03</b>	
							.022"	D <b>G8321-02</b> G <b>G8321-03</b>	
	7 6 6 7	  	-14°	+8°			.022"	D <b>G8321-12</b> G <b>G8321-13</b>	
								D <b>G8321-16</b> G <b>G8321-17</b>	
7 6 6 7	  	-20°	+8°			.022"	D <b>G8321-16</b> G <b>G8321-17</b>		
							D <b>G8381-06</b> G <b>G8381-07</b>		
7 6 6 7	  	-25°	+8°			.018"	D <b>G8381-06</b> G <b>G8381-07</b>		
						.022"	D <b>G8321-06</b> G <b>G8321-07</b>		

## TUBE LINGUAL MIM® AVEC CROCHET BOULE

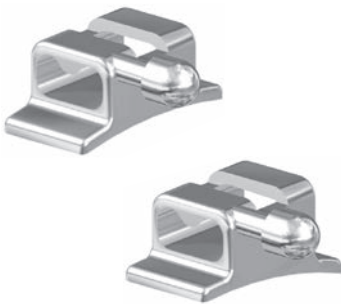

- G2846-02** Droit
- G2846-03** Gauche
- G2847-02** Droit rotation -8°
- G2847-03** Gauche rotation -8°

Les bases courbes s'adaptent tant au contour des premières que des secondes molaires.  
Indiqué pour fil double de .036".  
En paquets de 10

## TUBE MIM® POUR EXTRAORAL POUR ACTIVATEUR

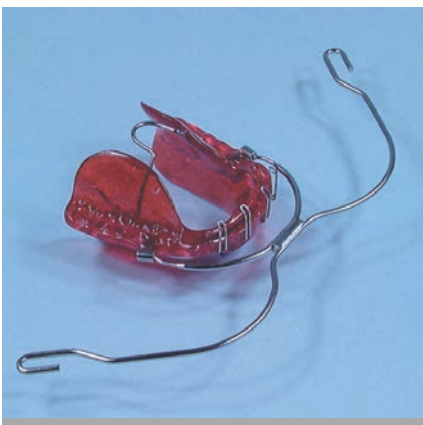

Fabriqué avec la technologie Metal Injection Moulding permet une grande rétention dans la résine. Très résistant. Dessin biseauté et confortable.  
En paquets de 10















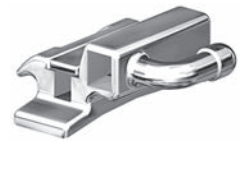











- A0761-45** Ø .045"
- A0761-51** Ø .051"



## TUBES VESTIBULAIRES MIM® CONVERTIBLES

La languette convertible soudée au laser assure une très bonne tenue tout en permettant la conversion avec l'instrument Leone P1090-00. Ils peuvent être livrés: en version à coller, présoudés sur les bagues **CALIBRA®** ou **WEB®**, ou soudo-brasés sur la base anatomique à coller **MAXI F2800-00**; (services gratuits pages 59, 110).

En paquets de 10

En paquets de 100, sur demande

				torque	rotat. tube rect.	diam. tube rond	slot tube rect.	tubes à souder
	$\frac{6}{6}$			0°		.045" occl.	.018"	D <a href="#">G8184-22</a> G <a href="#">G8184-23</a>
							.022"	D <a href="#">G8124-22</a> G <a href="#">G8124-23</a>
	$\frac{6}{6}$			0°		.051" occl.	.018"	D <a href="#">G8185-12</a> G <a href="#">G8185-13</a>
							.022"	D <a href="#">G8125-12</a> G <a href="#">G8125-13</a>
	$\frac{6}{6}$			-10°	+8°	.045" occl.	.018"	D <a href="#">G8484-22</a> G <a href="#">G8484-23</a>
							.022"	D <a href="#">G8424-22</a> G <a href="#">G8424-23</a>
	$\frac{6}{6}$			-10°	+8°	.051" occl.	.018"	D <a href="#">G8485-12</a> G <a href="#">G8485-13</a>
							.022"	D <a href="#">G8425-12</a> G <a href="#">G8425-13</a>
<b>tube auxiliaire .018"x.025"</b>								
	$\frac{6}{6}$			0°			.018"	D <a href="#">G8170-16</a> G <a href="#">G8170-17</a>
							.022"	D <a href="#">G8110-16</a> G <a href="#">G8110-17</a>
	$\frac{6}{6}$			-14°	+8°		.018"	D <a href="#">G8470-02</a> G <a href="#">G8470-03</a>
							.022"	D <a href="#">G8410-02</a> G <a href="#">G8410-03</a>
$\frac{6}{6}$			-25°	+8°		.018"	D <a href="#">G8470-06</a> G <a href="#">G8470-07</a>	
						.022"	D <a href="#">G8410-06</a> G <a href="#">G8410-07</a>	
<b>tube auxiliaire .018"x.025"</b>								
	$\frac{6}{6}$			0°		.045" occl.	.018"	D <a href="#">G8184-12</a> G <a href="#">G8184-13</a>
							.022"	D <a href="#">G8124-12</a> G <a href="#">G8124-13</a>
	$\frac{6}{6}$			0°		.051" occl.	.018"	D <a href="#">G8185-22</a> G <a href="#">G8185-23</a>
							.022"	D <a href="#">G8125-22</a> G <a href="#">G8125-23</a>
	$\frac{6}{6}$			-10°	+8°	.045" occl.	.018"	D <a href="#">G8484-12</a> G <a href="#">G8484-13</a>
							.022"	D <a href="#">G8424-12</a> G <a href="#">G8424-13</a>
$\frac{6}{6}$			-10°	+8°	.051" occl.	.018"	D <a href="#">G8485-22</a> G <a href="#">G8485-23</a>	
						.022"	D <a href="#">G8425-22</a> G <a href="#">G8425-23</a>	
$\frac{6}{6}$			-14°	+10°	.045" occl.	.022"	D <a href="#">G8424-32</a> G <a href="#">G8424-33</a>	

		⏏						
		<i>torque</i>	<i>rotat. tube rect.</i>	<i>diam. tube rond</i>	<i>slot tube rect.</i>	<i>tubes à souder</i>		
	6/6 6/6	0°		.045" ging.	.018" D G8184-02 G8184-03	.022" D G8124-02 G8124-03		
		0°		.051" ging.,	.018" D G8185-02 G8185-03	.022" D G8125-02 G8125-03		
	6/6	-10°	+8°	.045" ging.	.018" D G8484-02 G8484-03	.022" D G8424-02 G8424-03		
		-10°	+8°	.051" ging.	.018" D G8485-02 G8485-03	.022" D G8425-02 G8425-03		
		-20°			.022" D G8424-16 G8424-17			
	6/6	-25°	+8°	.045" ging.	.018" D G8484-06 G8484-07	.022" D G8424-06 G8424-07		
		-25°			.018" D G8485-06 G8485-07	.022" D G8425-06 G8425-07		
	6/6 6/6	0°			.018" D G8181-02 G8181-03	.022" D G8121-02 G8121-03		
	6/6	-10°	+8°		.018" D G8481-02 G8481-03	.022" D G8421-02 G8421-03		
		-20°	+8°		.022" D G8421-16 G8421-17			
	6/6	-25°	+8°		.018" D G8481-06 G8481-07	.022" D G8421-06 G8421-07		
					.022" G8421-07			
						.018" D G8481-06 G8481-07	.022" D G8421-06 G8421-07	



### **P1090-00** \*\*\* CONVERTISSEUR POUR TUBES CONVERTIBLES

Permet une simple conversion du tube rectangulaire après la mise en place de la seconde bague molaire. Autoclavable.  
Pointes de rechange, **P1090-01**, en paquets de 2





## VERROUS A SOUDER

En paquets de 10

En paquets de 100, sur demande



### maxillaire

		torque	ang.	mm	slot .018"	slot .022"
<b>2   1   1   2</b>						
			0°	2,5	D G	G2080-14 G2020-14
			0°	3,3	D G	G2080-34 G2020-34
<b>1   1   1</b>						
			0°	3,5	D G	G2086-14 G2026-14
			0°	4,4	D G	G2080-44 G2020-44
			+10°	+5°	3,3	D G G2421-02 G2421-03
			+22°	0°	3,3	D G G2480-04
<b>2   2   2</b>						
			0°	2,7	D G	G2080-24 G2020-24
			+5°	+10°	2,7	D G G2422-02 G2422-03
			+14°	+8°	2,7	D G G2482-02 G2482-03
<b>3   3   3</b>						
			0°	2,5	D G	G2080-14 G2020-14
			0°	2,7	D G	G2088-04 G2028-04
			0°	3,3	D G	G2088-14 G2028-14
			+7°	+5°	3,3	D G G2483-08 G2483-00
			-10°	+10°	3,3	D G G2423-02 G2423-03
			-10°	+15°	3,3	D G G2423-12 G2423-13
<b>5 4   4 5</b>						
			0°	2,7	D G	G2088-04 G2028-04
			0°	3,3	D G	G2088-34 G2028-34
			0°	2,0	D G	G2089-14 G2029-14
			0°	3,3	D G	G2084-01 G2024-01
			-7°	0°	3,3	D G G2489-01 G2429-11



### mandibulaire

		torque	ang.	mm	slot .018"	slot .022"
<b>2   1   1   2</b>						
			0°	2,0	D G	G2080-04 G2020-04
			0°	2,1	D G	G2080-05 G2020-05
<b>3   3   3</b>						
			0°	2,5	D G	G2080-14 G2020-14
			0°	2,7	D G	G2088-04 G2028-04
			0°	3,3	D G	G2088-14 G2028-14
			+7°	+5°	3,3	D G G2483-00 G2483-08
			-10°	+5°	3,3	D G G2423-06 G2423-07
			-10°	+10°	3,3	D G G2423-16 G2423-17
<b>5 4   4 5</b>						
			0°	2,7	D G	G2088-04 G2028-04
			0°	3,3	D G	G2088-34 G2028-34
			-7°	0°	3,3	D G G2484-05
			-15°	0°	3,3	D G G2485-05
			0°	2,0	D G	G2089-14 G2029-14
			0°	3,3	D G	G2084-01 G2024-01
			-17°	0°	3,3	D G G2489-15 G2429-15
			-22°	0°	3,3	D G G2489-05 G2429-25
<b>6   6   6</b>						
			0°	3,5	D G	G2086-14 G2026-14
			0°	4,4	D G	G2080-44 G2020-44

conseillés pour la technique Andrews

conseillés pour la technique Ricketts





## JOINTS POUR LE SOUDAGE AU LASER

Les joints pour le soudage au laser sont des dispositifs à présouder sur le côté lingual des bagues. Fabriqués selon la technologie **MIM**®, ils sont caractérisés par une géométrie particulière indiquée à accueillir le fil ou le bras de l'écarteur de manière de permettre le soudage au laser d'éléments ayant des épaisseurs différents. Les trois modèles consentent la construction d'écarteurs, d'arcs palatins et de quad helix d'une façon sûre grâce à la solidité des joints soudés.

En paquets de 10



**G0560-00**  
JOINT  
POUR ECARTEURS



**G0565-09**  
JOINT 0,9 mm  
POUR PREMOLAIRES



**G0570-09**  
JOINT 0,9 mm  
POUR MOLAIRES



*Les rebords du joint assurent l'union parfaite à la bague à l'aide d'une simple soudeuse*



*Le dessin du joint favorise le placement biomécanique correct du bras et l'hygiène de la zone*



*Particulier du logement du fil à l'intérieur du joint*



*Joint soudé au laser: l'endurance mécanique et la parfaite inoxydabilité sont assurées*

### TUBES RONDS



	mm		cond.
.036"	6,5	<b>G0533-36</b>	
.045"	5,5	<b>G0532-45</b>	10
.045"	9,5	<b>G0535-45</b>	

### TUBES POUR TECHNIQUE TWIN ARCH



**G0520-24**  
28,6 mm de long.  
Pour 2 fils de .011"  
Diamètre externe de .036"



### CROCHETS MIM®

Pour le blocage intermaxillaire post-chirurgical et pour la traction intermaxillaire. Bords arrondis. Positionnement avec la pince P1911-00.

### CANULES RONDES



		cond.
.036"	<b>G0525-36</b>	1 pièce de 30 cm
.045"	<b>G0525-45</b>	



**G0533-36**  
A souder. Diamètre interne .036"  
En paquets de 10

mm	pour arc .018"	pour arc .022"	cond.
2,0	<b>G9620-18</b>	<b>G9620-22</b>	10
2,0 ouverts	<b>G9650-18</b>	<b>G9650-22</b>	

## G2800-00 GRILLE LINGUALE DE MESTRE

Pour éviter les habitudes de succion ou la poussée de la langue.  
Facile à adapter et déjà polie.  
En paquets unitaires



## STOP A SERRER

Peut être mis en place sans enlever l'arc.  
Positionné sur l'arc on le serrera avec une pince à sertir robuste ou avec la pince universelle. Indiqué pour ressorts de traction et compression.

**G9225-18** pour arcs .018"x.025"

**G9228-22** pour arcs .022"x.028"

En paquets de 10



## G2820-00 CROCHETS LINGUAUX PROFIL HAUT

En paquets de 100



## BOUTONS LINGUAUX



**G2860-00**  
Base plate pour position centrale sur molaires



**G2865-00**  
Base courbe pour position mésiale sur molaires



**G2870-00**  
Base très courbe pour prémolaires

En paquets de 10

## CROCHETS POUR ELASTIQUES

**G2893-00** Courbes pour postérieures

**G2890-00** Droits pour antérieures

En paquets de 100

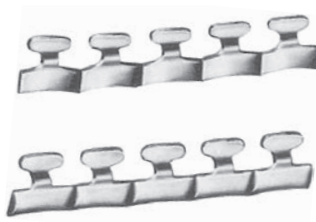

## CROCHETS LINGUAUX PROFIL BAS

**G2824-00** Pour molaires

**G2822-00** Pour canines et pré molaires

En paquets de 100



## G2850-00 APPUIS LINGUAUX

En paquets de 100



## G2810-00 OEILLETS POUR LIGATURES

En paquets de 100



## G9019-25 CROCHET A SERTIR FERME

Utile pour l'application de forces intra et extra-orales sur les arcs en acier extra dur élastique et super dur trempé de diamètre .019"x.025". A sertir à l'aide d'une pince P1911-00.  
En paquet de 10

